

Side step Side Step at your own peril. Instead, bring multidimensional, reverb-crushing modern design to your walls. Measuring eight feet tall, the 36" wide sections contain hollow channels, or ribs, allowing for up to three colors. Felt is best when it has space to breathe. Side Step attenuates noise as it enters into the ribs and then again once the frequencies are inside Hchamber. Numbers don't lie: regular wall panels typically have an NRC rating of 0.60 or less, Side Step though comes in at 1.05! Meaning you can use less square footage while gaining the aesthetic benefits.

Specifying Acoustics never Felt better.

Bringing our legendary innovation, attention to detail, speed, service, and value to PET felt.

Your Products & Our Purpose

Craft purposeful and beautiful acoustically absorbent products that help designers and builders easily create spaces that enable people to connect and be at their best.



Specifications

Product Name	Side Step
Content	100% Polyester (PET) with a minimum of 60% recycled content
Thickness	12mm
Width	36.25"
Height	47.5", 59.5", 95.5"
Max Depth	3.75"
Weight	1.0 lbs per sq ft
Edge Options	Exposed felt
Sound Performance	ASTM C423-17: NRC = 1.05
Fire Performance	Product made from Class A PET felt material tested under ASTM-84
Variations	Sonus Felt uses an industry standard felting process. Slight and consistent variations in color and "heathering" should be expected when using this sustainable material. Slight imperfections are within normal manufacturing tolerance and not visible in standard installations.
Environmental	Low VOC emissions, formaldehyde and phenol-free. Red List free.
Maintenance	Vacuum to remove any loose dirt or dust. You may use a soft or plastic bristle brush to loosen it. Avoid excess pressure. Compressed air can also be used to dust the material in difficult or large installations. If stains are present, you may saturate a lint-free cloth with a mild detergent or soap and water solution.
Warranty	10 years
Unit of Sale	Per section, minimum order quantity: 2

Construction & Hardware

Z Clip to Z Bar

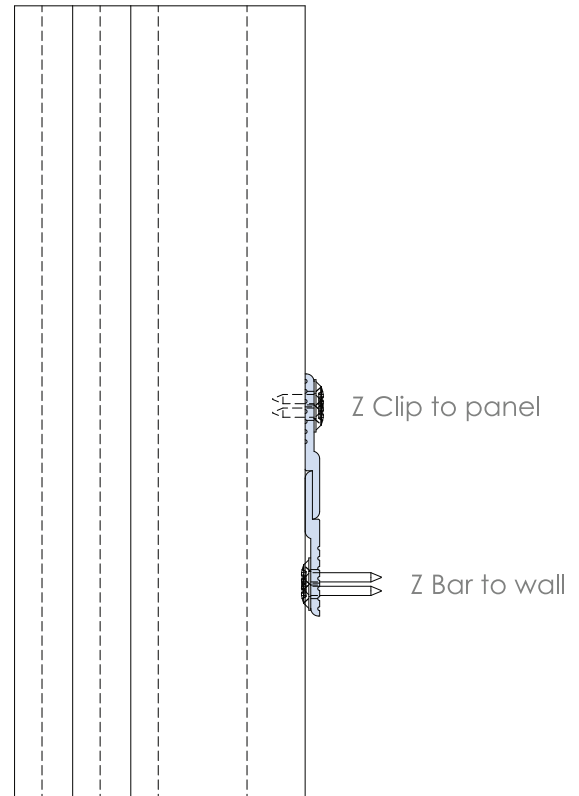
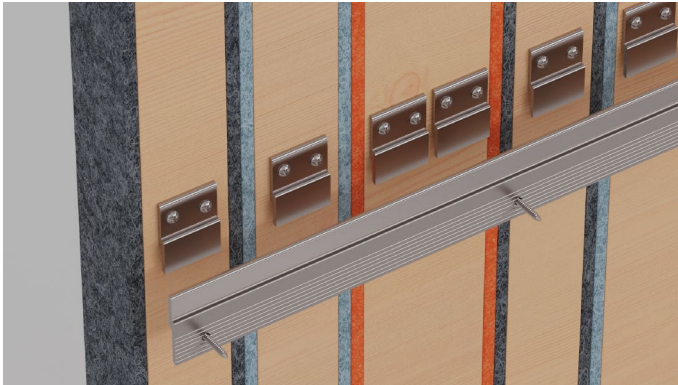
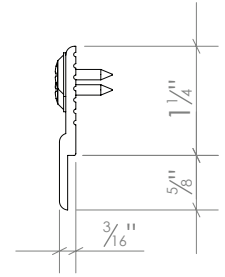
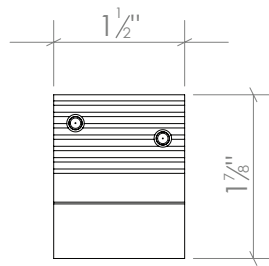
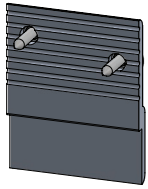
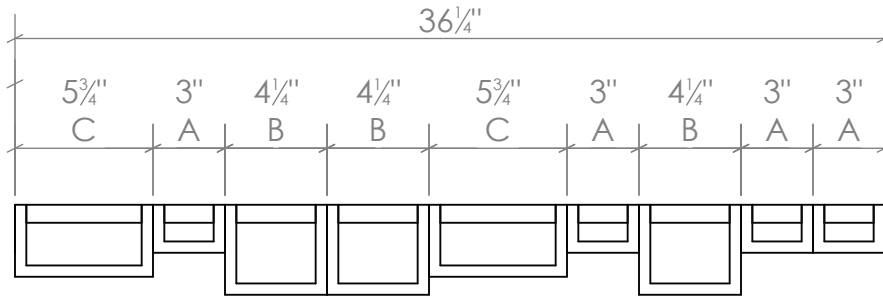

We recommend 1/2" round trim (contractor supplied) for final end pieces to cover assembly staples.

Colors



Test Results



Absorption Coefficient vs. Freq (Hz)

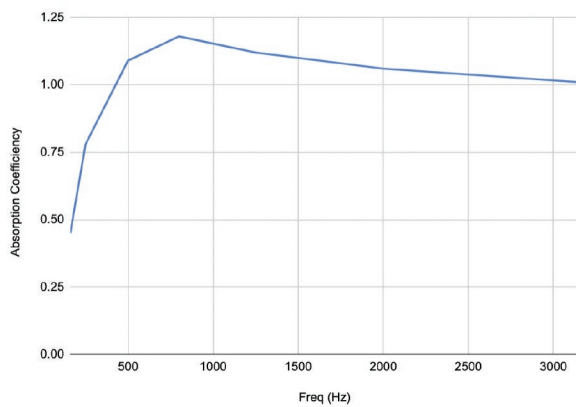

Freq (Hz)	Absorption Coefficient
160	0.45
250	0.78
500	1.09
800	1.18
1250	1.12
2000	1.06
3150	1.01
NRC	1.05

The Noise Reduction Coefficient (NRC) is calculated as the arithmetic average of the absorption coefficients in the shaded bands only (250, 500, 1250 & 2000 Hz).

ASTM C 423-17: Type A mounting - test specimen laid directly against test surface.